

NOTE: 1. CONTRACTION JOINTS SHALL NOT BE SPACED MORE THAN 15' APART.

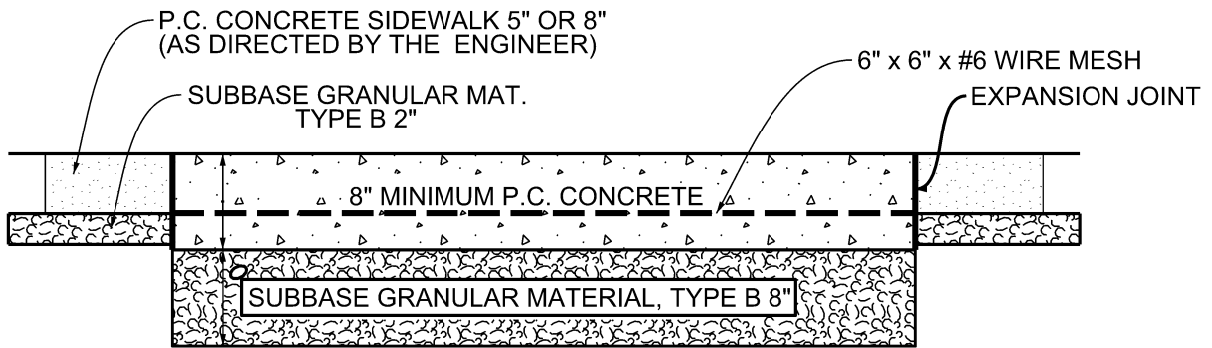

SECTION A-A

NOTES:

1. WHEN CARRIAGE WALK IS PRESENT, 6' OF CURB MUST BE UTILIZED FOR DEPRESSED CURB TRANSITION AREA TO CONFORM TO A.D.A. REQUIREMENTS. SEE SIDEWALK RAMP DETAIL FOR ADDITIONAL INFORMATION.
2. THE SECTION OF THE APRON WHICH IS UTILIZED AS PUBLIC WALK CANNOT HAVE A CROSS-SLOPE GREATER THAN 2%.
3. SEE CURB AND GUTTER AND SIDEWALK DETAILS FOR ADDITIONAL INFORMATION REGARDING EXPANSION JOINTS AND PINS, ETC.

VILLAGE OF ELK GROVE VILLAGE

COMMERCIAL / INDUSTRIAL DRIVE APRON - ON-STREET LOADING DOCK

